

ProCon® — P14G with NEXUS® pH Sensor Transmitter



The P14G Series pH sensors have a 4-20mA + RS485 direct outputs, thus eliminating the need for costly preamps or smart sensor interfaces.

- ✓ Double junction reference extends sensor life and protects against poisoning ions
- ✓ Durable crack resistant glass enhances performance and increased reliability
- ✓ Maximum chemical resistance provided by a rugged PP or PPS body materials
- ✓ Operates in sub-zero temperatures down to 14°F (-10°C).
- ✓ Advanced electronic diagnostics
- ✓ Superior glass electrode technology result in an industrial sensor with unequalled durability and reliability

- ✓ 4-20mA Output
- ✓ Temperature Compensated
- ✓ Double Salt Bridge
- ✓ No Preamp Required
- ✓ High Accuracy
- ✓ Quick Response Time
- ✓ 3/4" NPT Connection
- ✓ PP or PPS Body Materials
- ✓ RS 485 Modbus Communication

Engineered for accuracy, ruggedness and longevity in general process applications

The robust sensor design of the versatile ProCon® P14G confidently offers long-term reliability with fast response times and high accuracy in a wide range of general process applications.

These sensor transmitters are have been specifically engineered with a double ceramic reference diaphragms that provide highly responsive pH indication.

The double salt bridge junction coupled with the PTFE reference technology is the foundation for all P14G series electrodes. The inner reference chamber is charged with potassium chloride (KCl) gel.

All measurement functions are combined in one compact body — measuring electrode, temperature sensor and an inner reference chamber.

The 2-wire 4-20mA, 4-wire or 4-20mA + RS485 output options simplify calibration and communication with remote displays and controllers.

Model Selection

P14G — General pH Sensor				
Part Number	Material	Output	Type	Connection
P14G-P-D-1-F-M	PP	4-wire (for ProCon® display)	Flat	M12
P14G-P-D-1-B-M	PP	4-wire (for ProCon® display)	Bulb	M12
P14G-P-M-1-F-M	PP	4-20mA (2-wire, std)	Flat	M12
P14G-P-M-1-B-M	PP	4-20mA (2-wire, std)	Bulb	M12
P14G-P-S-1-F-M	PP	RS485 + 4-20mA	Flat	M12
P14G-P-S-1-B-M	PP	RS485 + 4-20mA	Bulb	M12

Last digit: "M" for M12 Connection (std), "F" Flying Lead - consult factory



Smart Sensor Technology

Advanced electronic circuitry stores pH data for automatic sensor recognition and trouble-free calibration when connected to the ProCon® Controller.

Outputs

1. 4-20mA 2-Wire
2. 4-20mA + RS485

Both the measuring and reference electrodes are encapsulated within the non-porous advanced KCl infused polymer known as Nexus®.

Less Calibration and Maintenance

Most sensors require on-going recalibration and are prone to premature failure due to what is known as gradient drift, or sensor drift.

The Nexus® series is a solid reference material. Poisoning or leaching of the reference electrolyte that occurs in standard sensor is greatly reduced.

The Nexus reference helps to eliminate the need for ongoing maintenance or cleaning requirement due to fouling or film build up removal which occurs with many process applications with traditional pH sensors.

Faster Response — Longer Lasting

The solid Nexus® reference provides for faster response time to changing pH values since there is no requirement for a junction.

- ✓ No Costly Preamps Required
- ✓ Direct 4-20mA & RS485 Outputs

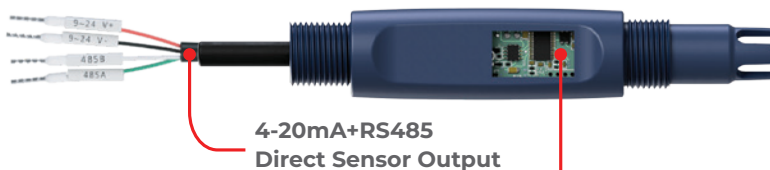
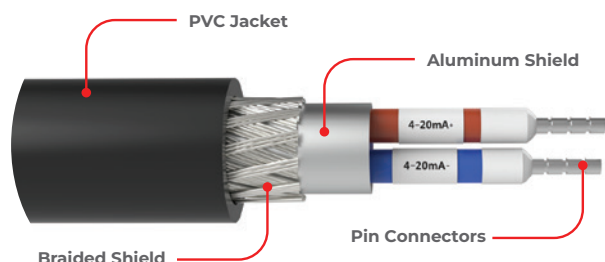

Advanced electronic circuitry stores pH data for automatic sensor recognition and trouble-free calibration when connected to the ProCon® Controller

Enhanced chip technology allows for remote calibration as well as diagnostic data

Data analysis and direct 4-20mA signal or RS485 Digital outputs

Integral Preamp

2-wire 4-20mA + RS485 Modbus direct sensor to controller connection eliminates the requirement for a preamp.

Digital output removes the need for high impedance cable — longer distances without compromising accuracy.

Nexus® technology

- Solid KCl infused reference junction
- Eliminates reference poisoning/leaching
- Extended life expectancy



Specifications

Measurement Range	
pH	0 – 14
Output Signal — No Preamp Required	
2 Wire Loop Powered 4-20mA + RS 485 Direct Sensor Output	
Accuracy	
7.00 ± 0.25	
Operating Temperature	
14 to 176°F -10 to 80°C Automatic Temperature Compensation	
Maximum Pressure	
150 Psi at 140°F (60°C) — See Pressure vs. Temp Graph	
Design	
Sensor body	PP Polypropylene (std) Ryton® PPS
Reference System	Ag / AgCl / KCl Double Salt Bridge
pH electrode	Blue Glass Flat Bulb
Reference	Porous Ceramic + PTFE Teflon®
Connection	3/4" NPT
Measuring Electrode Resistance	< 600 MΩ
Impedance Range	102 – 675 MΩ
Temperature Compensation/Output- 4-20 + RS485 Model	
Pt-1000 (Std)	
Pt-100	

Temperature Control

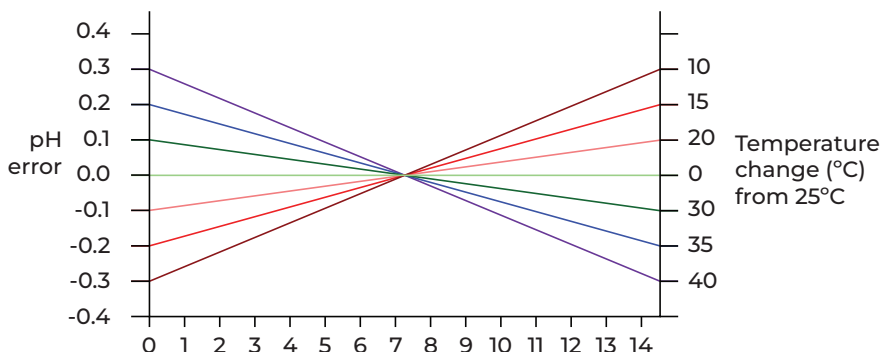

Temperature vs. Pressure

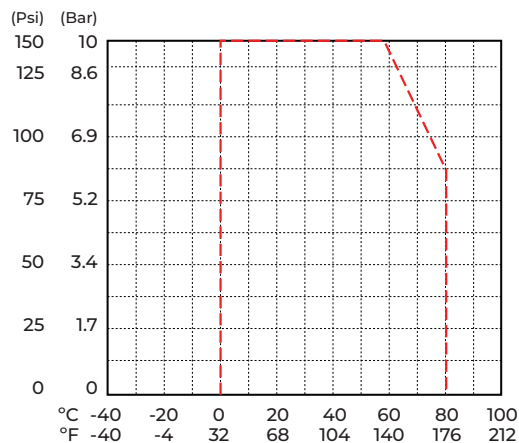

In-line Mounting

1. Avoid vertical installation. (air may be present)
2. Optimum installation 15° above horizontal.
3. Process liquid should flow upward. (for downward flow ensure backpressure is present in order to avoid air within pipe)

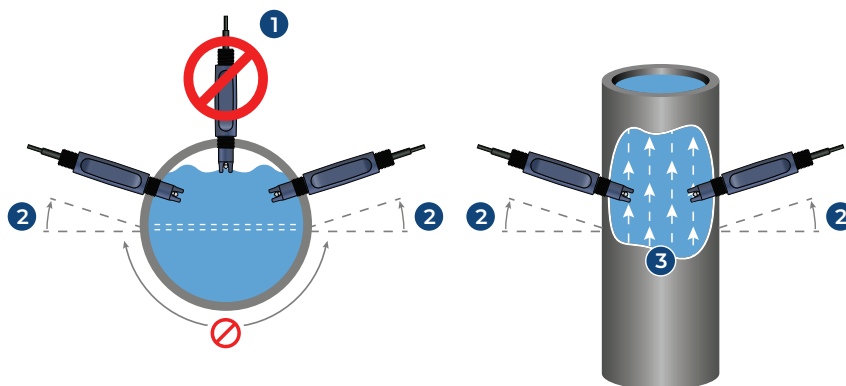

Typical Application

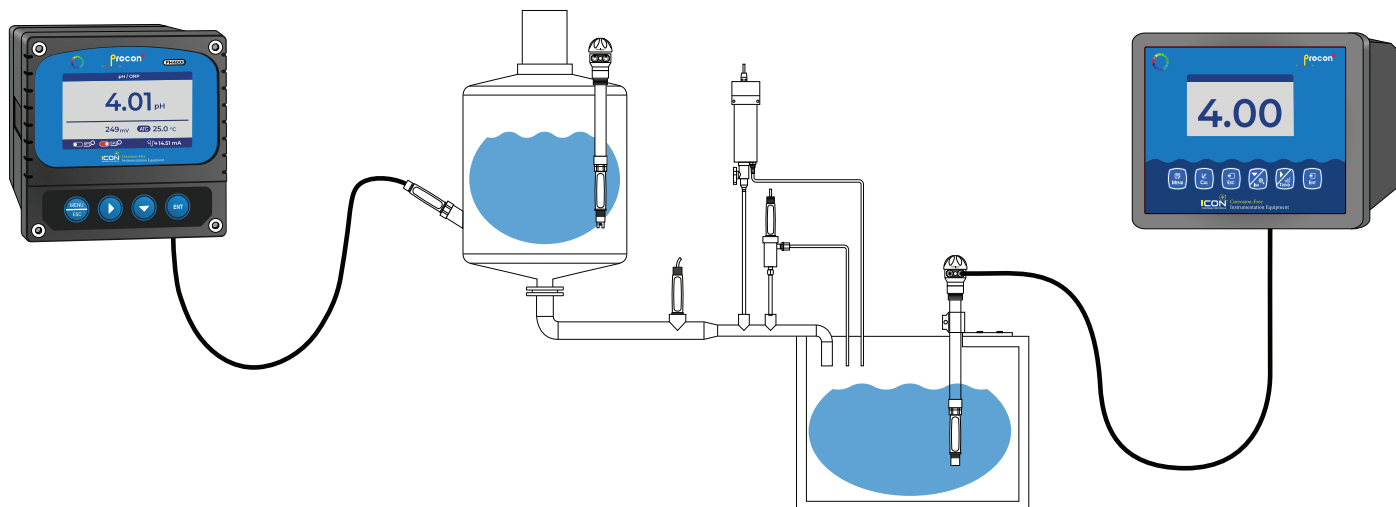

Cable Options

The ProCon® series offer complete flexibility of cabling options throughout the range. All cables are shielded against spurious EMF and are potted inside the sensor ensuring environmental protection.

The standard cable length for most sensors is 5m (15 ft). However, cables can be supplied as any continuous size up to 20m (66 ft).

Standard accessories include submersion couplers, typically used with extension cables for direct connection to the ProCon® Controllers.

Extension cables also permit distances between sensor and instrument of up to 30 m (100 ft.) without external preamplifier.



M12
Quick
Connection

Temperature compensation

The temperature compensator enables sensor to adjust for temperature effects on the glass pH electrode output.

The sensor can also use this measurement to compensate for solution pH temperature effects.

Sensors can be ordered with integral temperature sensors. The integral temperature compensator is available in two outputs — Pt 1000 (std) and Pt 100.

** Temperature outputs on 4 and 6 wire versions only.*

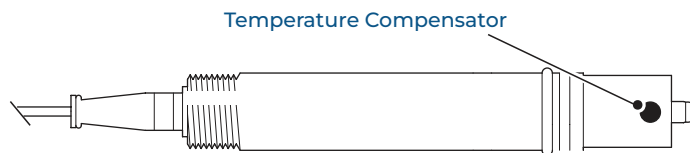

Typical Installations

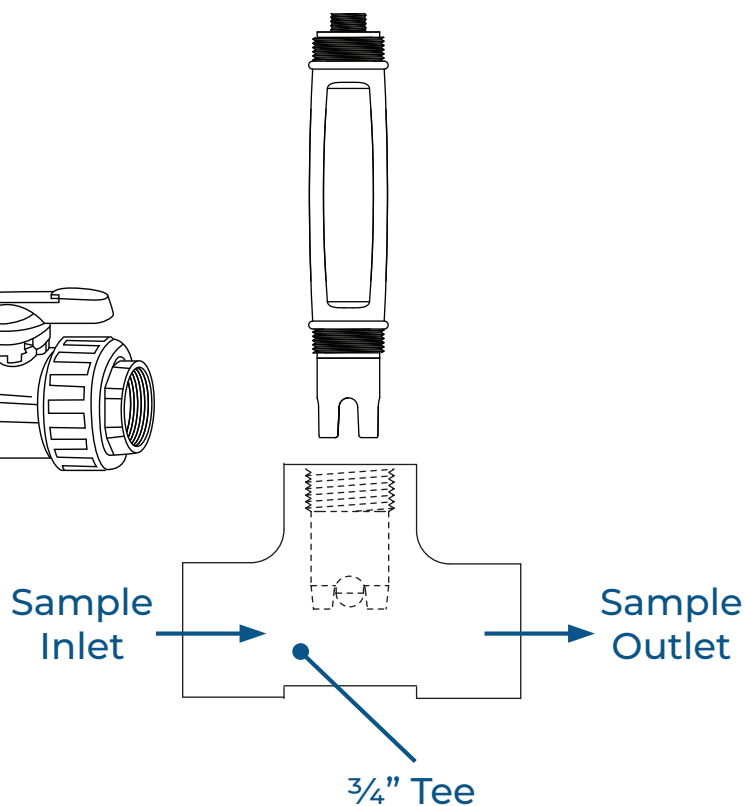
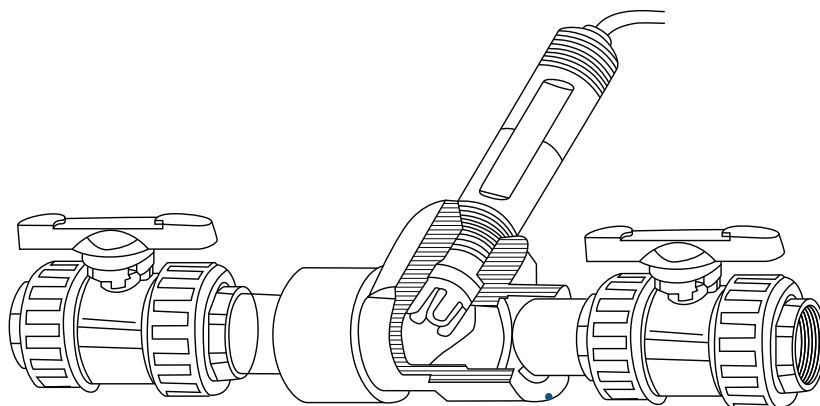

Wiring — Flying Lead

4-20mA 2-wire

- 1 Blue: mA-
- 2 Brown: mA+



4-20mA 4-wire

- 1 Transparent: 4-20mA
- 2 Black (thick): Ref
- 3 Red: Temperature
- 4 Black: Temperature

Connects directly to ProCon® controller

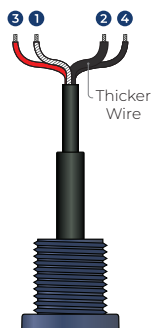

4-20mA + RS485 Output

- 1 Red: 9-24VDC +
- 2 Black: 9-24VDC -
- 3 Transparent: 4-20mA
- 4 Black (thick): Ref
- 5 Green: RS 485 A
- 6 White : RS 485 B



Wiring — M12

4 Pin M12 Connection

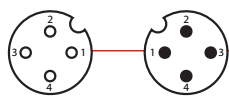

M12 - Male M12 - Female



4-20mA | 4 Pin

Color	Description
Pin 1 - Brown	4-20mA +
Pin 2 - Blue	4-20mA -

4-20mA + Controller | 4 Pin

Color	Description
Red	Temperature
Black	Temperature
Black (Thick)	Reference
Transparent	4-20mA

8 Pin M12 Connection



M12 - Female



4-20mA + RS485 | 8 Pin

Color	Description
Red	9-24 VDC +
Black	9-24 VDC -
Transparent	4-20mA
Black (Thick)	Reference
Green	RS485 A
White	RS485 B

4 Pin IO - Link Connection



I-O Link | 4 Pin

Pin	Description
Pin 1	24 VDC +
Pin 2	
Pin 3	GND
Pin 4	4-20mA

Dimension

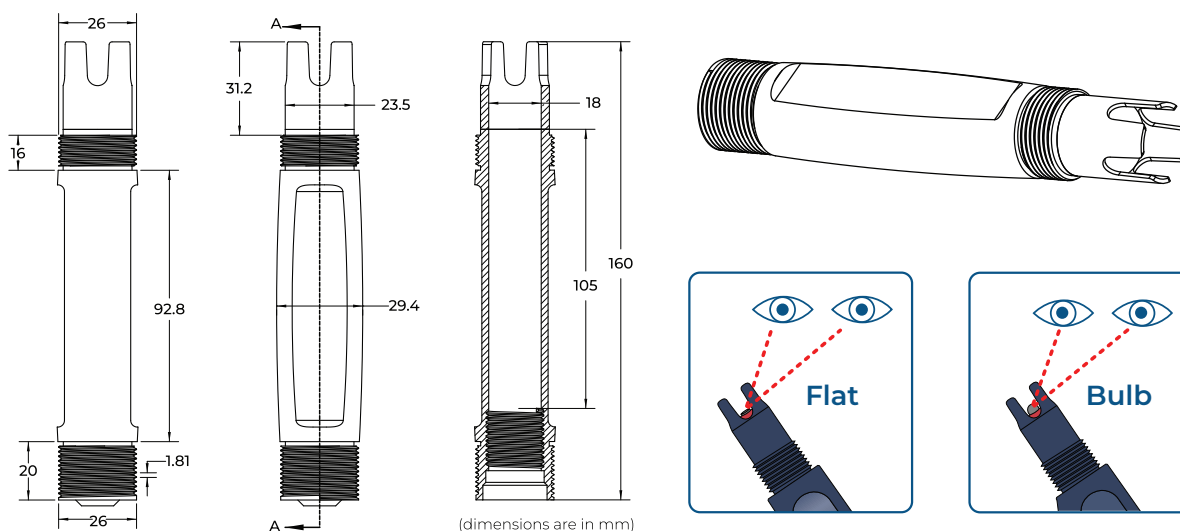

Fittings

Easy Install Clamp On Pipe Saddles

Part Number	Material	Size	Seal	Thread	Connection
PSA-2	PVC	2"	FPM	3/4" NPT	PVC
PSA-3	PVC	3"	FPM	3/4" NPT	PVC
PSA-4	PVC	4"	FPM	3/4" NPT	PVC
PSA-6	PVC	6"	FPM	3/4" NPT	PVC
PSA-8	PVC	8"	FPM	3/4" NPT	PVC

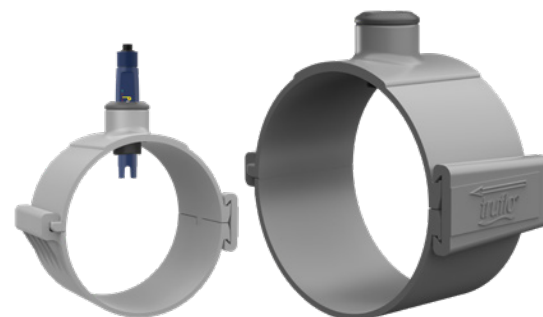

True Union Tee Fitting

Part Number	Material	Size	Seal	Thread	Connection
TUPA-PV-5	PVC	1/2"	FPM (std) EPDM	3/4" NPT	Socket NPT
TUPA-PP-5	PP	1/2"	FPM (std) EPDM	3/4" NPT	Butt NPT
TUPA-PF-5	PVDF	1/2"	FPM (std) EPDM	3/4" NPT	Butt NPT
TUPA-PV-7	PVC	3/4"	FPM (std) EPDM	3/4" NPT	Socket NPT
TUPA-PP-7	PP	3/4"	FPM (std) EPDM	3/4" NPT	Butt NPT
TUPA-PF-7	PVDF	3/4"	FPM (std) EPDM	3/4" NPT	Butt NPT
TUPA-PV-1	PVC	1"	FPM (std) EPDM	3/4" NPT	Socket NPT
TUPA-PP-1	PP	1"	FPM (std) EPDM	3/4" NPT	Butt NPT
TUPA-PF-1	PVDF	1"	FPM (std) EPDM	3/4" NPT	Butt NPT
TUPA-PV-15	PVC	1 1/2"	FPM (std) EPDM	3/4" NPT	Socket NPT
TUPA-PP-15	PP	1 1/2"	FPM (std) EPDM	3/4" NPT	Butt NPT
TUPA-PF-15	PVDF	1 1/2"	FPM (std) EPDM	3/4" NPT	Butt NPT
TUPA-PV-2	PVC	2"	FPM (std) EPDM	3/4" NPT	Socket NPT
TUPA-PP-2	PP	2"	FPM (std) EPDM	3/4" NPT	Butt NPT
TUPA-PF-2	PVDF	2"	FPM (std) EPDM	3/4" NPT	Butt NPT

